

North Somerset Show

6th May 2024



Blacksmith Competition

To be held at the North Somerset Showground,
Wraxall (on the B3130) near Bristol

Judge:

Mr D Mallett FWCB LWCB, MOD Lyneham, Wiltshire

We are a qualifying Show for the NBCC Blacksmith of the Year competition.

Hosted by:

The Guild of Wrought Ironworks
Craftsmen of Wessex

Chief Steward: **Mr Keith Mahoney AWCB**

Enquiries to Keith Mahoney AWCB, Tel: 07771 121144

email: keithmahoney02@ymail.com

Kindly Sponsored by:

Mr K Mahoney AWCB, The Pound, Bromham, Wilts.

Entry fee £6.00 (inc VAT)

Online entries close 22nd April 2024 – late entries accepted

CLASSES

1. INDOOR
2. OUTDOOR
3. ARTISTIC

- For the above classes, competitors are to display work previously made by themselves in their own workshop.
- No limit to the number of entries
- Entries to be delivered by 8:00am on Show day unless previously arranged at the Stewards discretion.
- Entries should be clearly marked with the name and address of the competitor in a plain, sealed envelope that is marked on the outside with the class description.
- Classes 1, 2 and 3 are qualifying classes for the Worshipful Company of Blacksmiths Competitions and entries from students and apprentices are welcome.

Prize money for above Classes: 1st Prize: £35.00, 2nd Prize: £23.00, 3rd Prize: £17.00

4. LIVE FORGING

An item of door furniture, e.g. Door knocker, hinge, latch, letterbox, bell, door handle or doorknob etc.; size of item is up to the competitor.

All competitors to bring their own materials, tools, safety equipment; no special tools are required.

Time allowed 1 hour 15 minutes, including clean up time.

Time will start when the metal is placed in the fire.

Starting time to be arranged by the Steward on the day of the Show.

Open Live Competition Prize Money: 1st Prize: £75.00, 2nd Prize: £50.00, 3rd Prize: £25.00

This is the first qualifying Show for the NBCC Blacksmith of the year competition in association with the Worshipful Company of Blacksmiths.

The Worshipful Company of Blacksmiths (WCB) award an additional cash prize to the champion and reserve champion in the Static Display and the Live competitions. The WCB will make equal payments to both Static and Live competition champions and equal payments to Static and Live reserve champions.

5. STUDENT & APPRENTICE LIVE FORGING

Hasp and staple

A set piece to be made from the drawing supplied by the judge. All material to make this item will be provided on the day.

See drawing overleaf

Student/Apprentice Live Competition Prize Money:

1st Prize: £50.00, 2nd Prize: £30.00, 3rd Prize: £20.00

Kindly sponsored by Mr D Mallett FWCB LWCB, MOD Lyneham, Wiltshire

The Frank Day Trophy

Open to all Students/Apprentices and Blacksmiths with 3 years or less experience/training in the Blacksmiths craft entering a piece in classes 1, 2 or 3.

This competition will be run at the North Somerset and Dorchester County Shows this year as well as at the Blacksmith Guild AGM. The winners from each Show and the AGM will be judged again to confirm an overall winner.

The overall winner will be invited to receive the trophy at the worshipful Company of Blacksmiths Award Lunch held in the City of London during October.

The award consists of the Frank Day Trophy on which the winner's name will be engraved and a framed certificate recording the winning of the trophy together with a **cash prize**. The Guild can arrange for the winner to have publicity photos taken with the trophy for inclusion in their portfolio.

- 1) This highly respected trophy is open to all candidates whether they are Guild Members or not
- 2) Candidates must have 3 years or less training or experience in Blacksmithing
- 3) Entry to this class is free and candidates may enter more than one item
- 5) Candidates name to be printed inside an unmarked envelope and securely attached to each item
- 6) The winning entries will be judged again, using NBCC guidelines, at the guild's AGM by a panel of three judges. In the event of a tie, the master of the Guild will make the final decision

HAIR AND STAPLE.

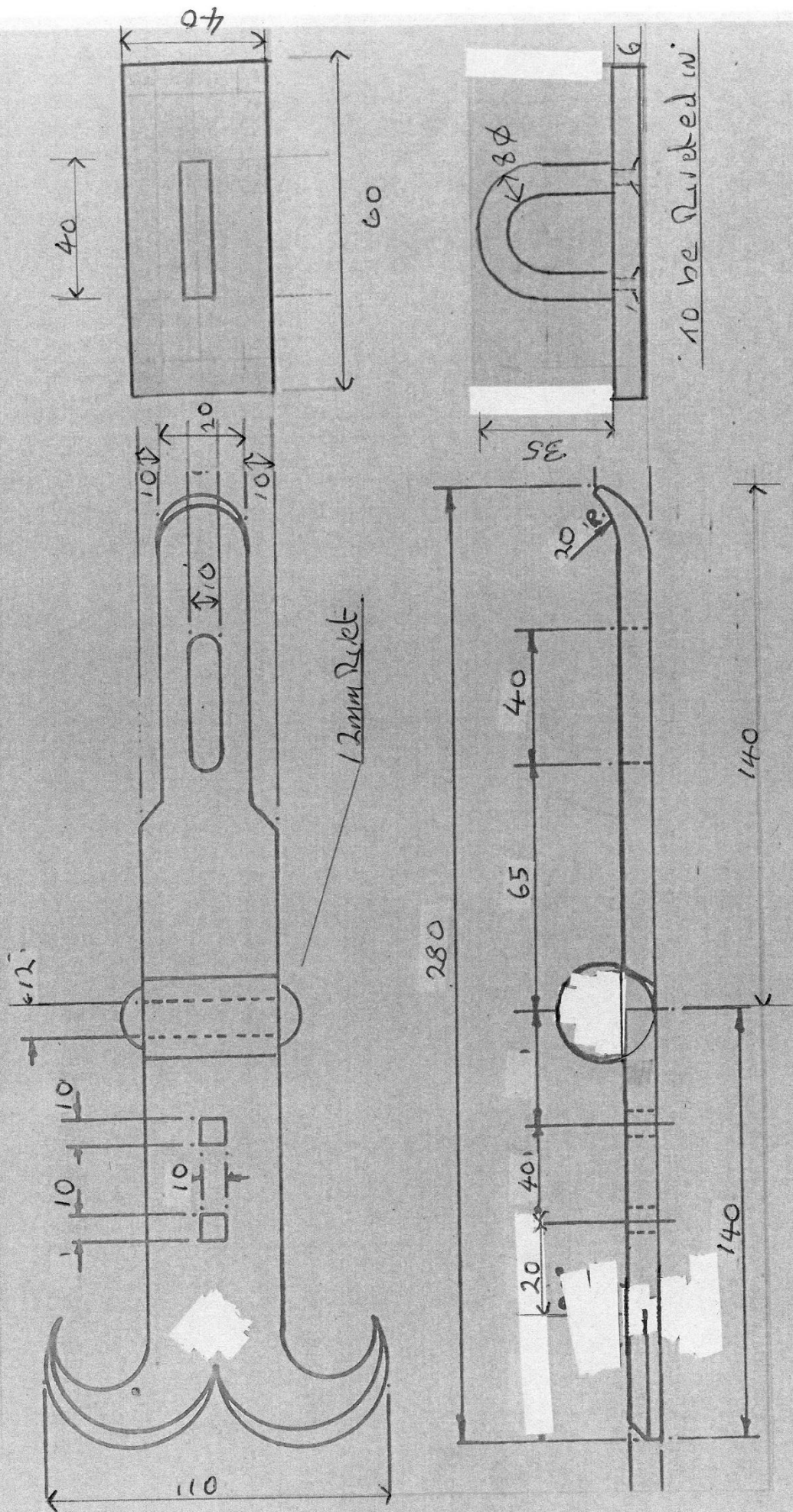

NOT TO SCALE: ALL IN M.M'S.

NATIONAL BLACKSMITHS' COMPETITIONS COMMITTEE
Champion Blacksmith of the Year and Champion Live Blacksmith of the year.

Points will be awarded at each of the qualifying Shows:

Winners of the Championship: 10 points and a framed certificate

Reserve Champion: 4 points and a framed certificate

Competitors may enter more than one piece at a Show but all entries must be judged and marked individually. Marks for several entries cannot be averaged or aggregated. The Blacksmith resident in the UK gaining most points in each category throughout the year will be declared Champion Blacksmith or Champion Live Blacksmith of the year.

Competitors may enter pieces for more than one Show and it is not necessary for the same piece to be entered for each Show but entries must have not won the NBCC Award in previous years.

The Champion Blacksmith will be awarded a challenge trophy which he/she holds for the year, a framed certificate and a cash prize. In addition, a framed certificate will be awarded to the runner-up.

The trophy must be returned to the Clerk of the Worshipful Company by the 1st October of the year in which it was won. The Champion Live Blacksmith will be awarded a framed certificate and a cash prize. The official presentation will be held at the Worshipful Company of Blacksmiths' Award Lunch.

CONDITIONS OF COMPETITION

1. The decision of the Judge is final.
2. Whilst every care shall be taken in protecting entries, we shall not accept any responsibility whilst items are in our possession.
3. Entries are not to be removed before 6.00pm on the Show day without the Stewards approval.
4. Protests must be submitted to the Show Steward within one hour of the occurrence and accompanied by a deposit of £5.00.
5. Prize winning entries from previous North Somerset Shows will not be accepted for entry, but can be displayed.
6. Only the following items will be supplied for live forging competitors: FORGE, FUEL, ANVIL AND VICE.
7. Live forging: Starting times will be arranged by the Steward on the day of the Show.
8. Competitors must bring their own tools and unworked materials.
9. Competitors are responsible for using safe working practises and using appropriate safety wear including spectacles, etc.
10. One vehicle pass and two exhibitor passes will be issued per exhibitor. Additional exhibitor passes must be ordered and paid for on this form at £17.00 each for adults, £5.00 for children (6-16). Any person travelling in a vehicle who does not have an exhibitor pass will have to pay the full Show day admission price (£21 adults, £9 children)

Competitors who are entering Classes 1 to 5 are welcome to exhibit other examples of their own work in the Marquee for display purposes only.

Entries can be made online at:

www.nsas.org.uk/north-somerset-show/blacksmiths/

Or alternatively, post in the enclosed paper entry form

Entries will be accepted up to 8.00am on the day of the Show
(for entries after 22nd April, please contact Keith Mahoney directly)